

GPPH PRODUCTS

PRO **INOX** | **PLUS** **INOX** | **ECO** | **XWT** | **BSC** | **DIY** | **MWT** | **SOG**



make **WELDING**
SIMPLE again



OFFER 2023

PROFESSIONAL WELDING TABLES



MADE IN POLAND

TABLE OF CONTENTS

1. WELDING TABLES – TRADITIONAL	
o PRO, PLUS, and ECO series – technical parameters	4
o PRO, PLUS, and ECO series – dimensions and price list – tables with legs on feet	6
o PRO, PLUS, and ECO series – dimensions and price list – tables with legs on wheels.....	7
o PRO, PLUS, and ECO series – stainless steel covers	8
2. WELDING TABLES – STAINLESS	
o INOX series – technical parameters	9
o INOX series – dimensions and price list – tables with legs on feet	11
o INOX series – dimensions and price list – tables with legs on wheels.....	12
3. WELDING TABLES – MODULAR	
o MWT series – technical parameters	13
o MWT series – dimensions and price list	14
4. WELDING TABLES – WELDING & ASSEMBLY TABLES	
o BASIC series – technical parameters	15
o BASIC series – dimensions and price list – tables with legs on feet	16
o BASIC series – dimensions and price list – tables with legs on wheels	17
o DIY series – technical parameters and price	18
o DIY series – toolkits	19
5. WELDING TABLES – LIFTING (with hydraulic lifting system)	
o XWT series – technical parameters	20
o XWT series – dimensions and price list	22
6. GRINDING-WELDING STATION	
o SOG series – technical parameters	24
o SOG series – technical parameters and price list	25
7. TOOLS	
o PRO series tools	26
o PLUS series tools	27
o ECO series tools	28
o Universal tools	29
o Tool trolleys	30
o Tools – price list	33
o Toolkits	34

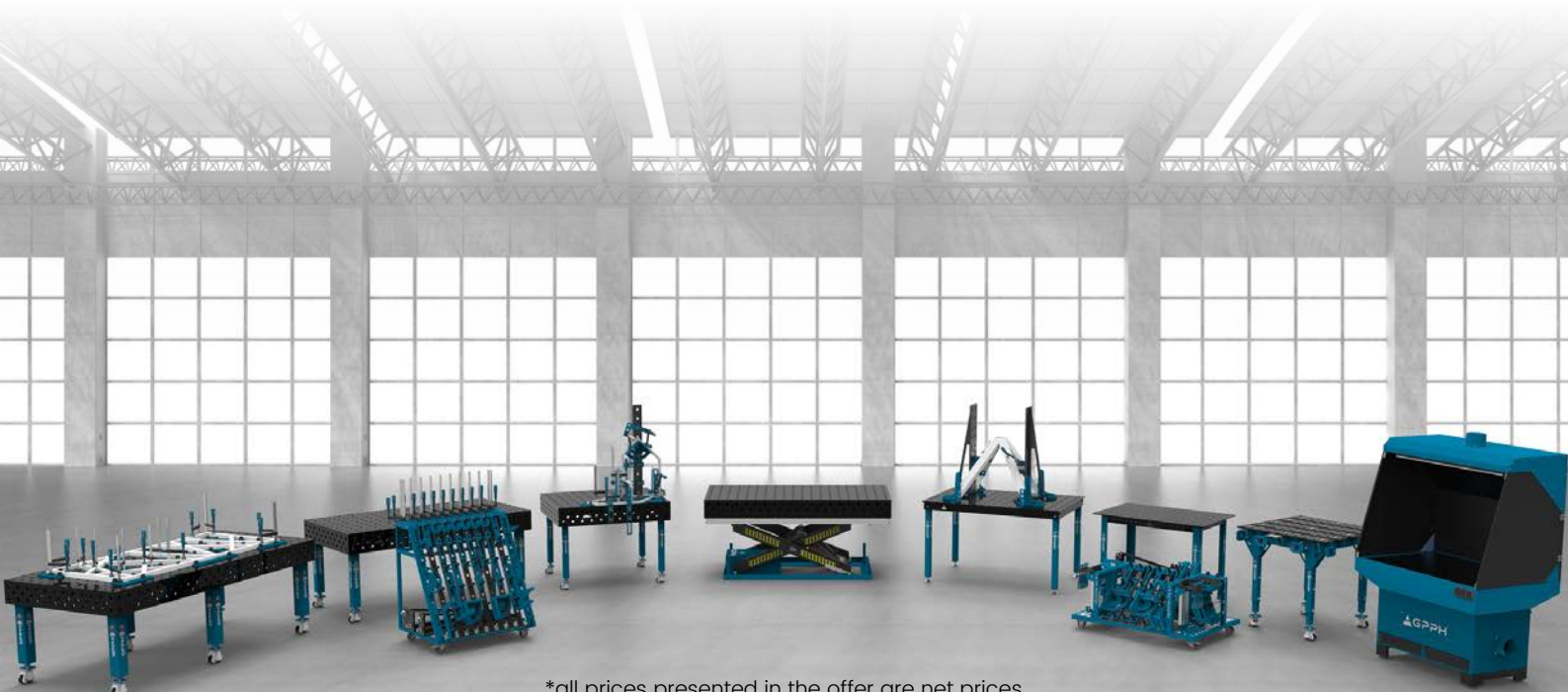

WELDING TABLES – TRADITIONAL

PRO, PLUS, and ECO series – technical parameters

Traditional GPPH Welding Tables come in three series: **PRO**, **PLUS**, and **ECO**. Each of them is in as many as 10 versions of dimensions.

You will use them wherever precision during welding is needed. For example, you can use it for manual or robotic welding. As a result, your constructions will finally be made accurately, without unnecessary corrections!

It also ensures ergonomic and fast work while maintaining the precision and repeatability of the structures. All tables are available with legs on feet or legs on wheels – the choice is up to you!

Depending on your preferences, you can choose **PRO**, **PLUS**, and **ECO** Welding Tables in hole systems:

- fi 28 mm in a 100x100 mm grid
- fi 28 mm in a diagonal grid
- fi 16 mm in a 100x100 mm grid
- fi 16 mm in a diagonal grid
- fi 16 mm in a 50x50 mm grid

Tables are made of material S355J2+N according to ISO 2768-1. Each table top has an engraved scale. The engraved scale is vertical and horizontal lines in a 100x100mm grid. It is a reference point when laying the constructions and when assembling tools. Using measuring tools, you can set your structure correctly to get the required dimension.

All tables have ribs, which results in a perfectly flat work surface. Ribs are arranged every 400 mm on average. The massive and rigid foundation of the table top guarantees the highest stability during use and protection against deformation. Tables sidewalls have a height of 200 mm and are executed with a deviation tolerance of $\pm 0.3^\circ$.

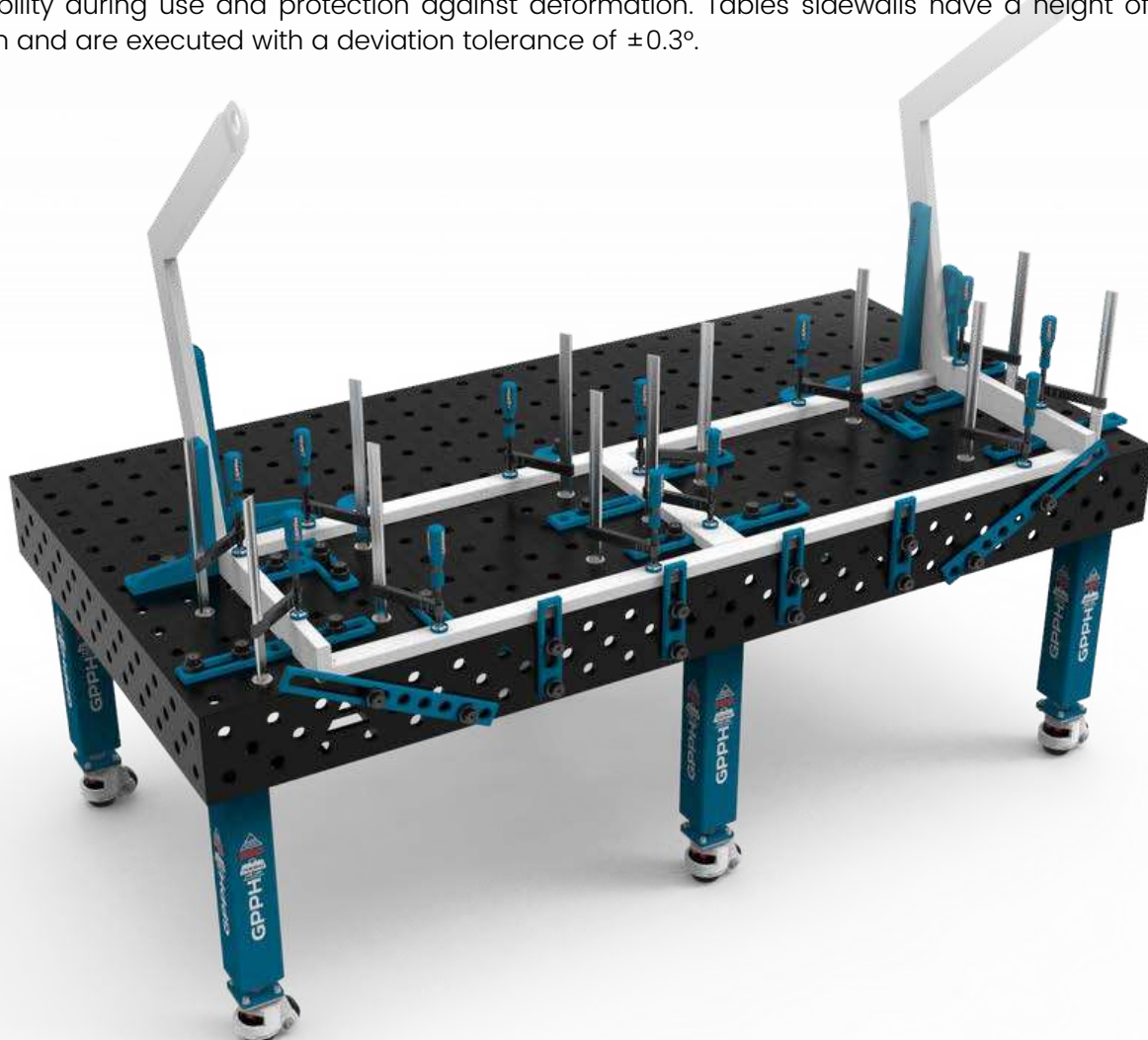

WELDING TABLES – TRADITIONAL

PRO, PLUS, and ECO series – technical parameters

Check the table below for the differences between the series of GPPH welding tables:

PARAMETER	PRO SERIES	PLUS SERIES	ECO SERIES
Tolerance on flatness for a table (on the whole worktop)*	±0,3 mm	±0,3 mm	±0,5 mm
Three grids of holes on the 4 sides	✓	✓	✓
Table top thickness	15 mm	12 mm	8 mm
Chamfered and milled holes	✓	✓	✗
Chamfered holes from bottom	✓	✓	✗
Holes manufacturing tolerance	+0,05 mm	+0,05 mm	±0,1 mm
Leg profile	100x100x4 mm	80x80x4 mm	60x60x4 mm
Capacity	700 kg / leg	500 kg / leg	250 kg / leg
Total load capacity for a table with 4 legs	2 800 kg	2 000 kg	1 000 kg
Total load capacity for a table with 6 legs	4 200 kg	3 000 kg	1 500 kg
Total load capacity for a table with 8 legs	5 600 kg	4 000 kg	2 000 kg
Milled table top edges	✓	✓	✗
Number of dimensional versions	10 versions	10 versions	10 versions

PRO, PLUS and ECO welding tables are available in the following sizes: 3000x1480 mm, 2400x1200 mm, 2000x1000 mm, 1500x1480 mm, 1500x1000 mm, 1200x1200 mm, 1200x1000 mm, 1200x800 mm, 1000x1000 mm, 1000x1000 mm.

To work on the PRO series welding tables, you will use milled tools from the PRO series, and for the PLUS and ECO series welding tables – tools from the PLUS series. Thanks to them, you can precisely make any 2D flat and 3D spatial construction. And all this in much less time! You will find the tool PRO series on page 26 and the PLUS series on page 27.

WELDING TABLES – TRADITIONAL

PRO, PLUS, and ECO series – dimensions and price list – tables with legs on feet

Price list for tables with legs on feet with a fi 28 mm or fi 16 mm hole system in a 100x100 mm grid:

Table top size [mm]	Net price PRO SERIES	Net price PLUS SERIES	Net price ECO SERIES
1000x600			
1000x1000			
1200x800			
1200x1000			
1200x1200			
1500x1000			
1500x1480			
2000x1000			
2400x1200			
3000x1480			

Price list for tables with legs on feet with a 28 mm or 16 mm hole system in a diagonal grid and for tables with a 16 mm hole system in a 50x50 mm grid:

Table top size [mm]	Net price PRO SERIES	Net price PLUS SERIES	Net price ECO SERIES
1000x600			
1000x1000			
1200x800			
1200x1000			
1200x1200			
1500x1000			
1500x1480			
2000x1000			
2400x1200			
3000x1480			

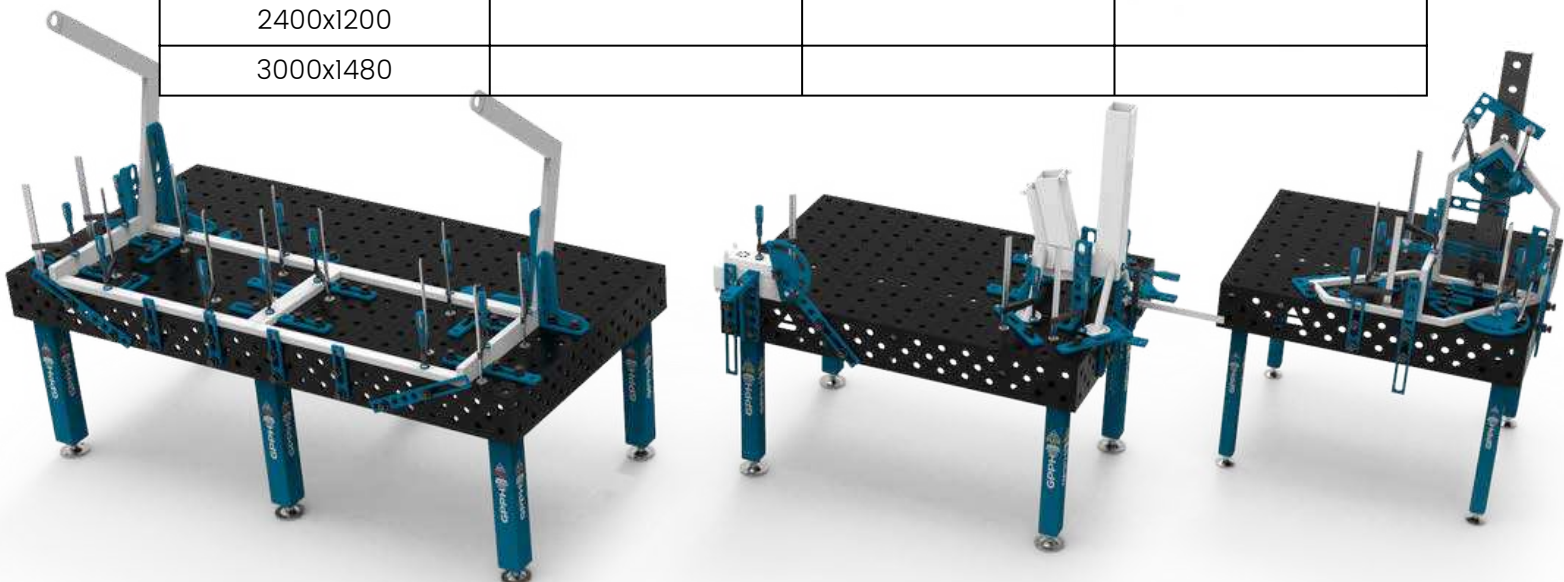

WELDING TABLES – TRADITIONAL

PRO, PLUS, and ECO series – dimensions and price list – tables with legs on wheels

Price list for tables with legs on wheels with a fi 28 mm or fi 16 mm hole system in a 100x100 mm grid:

Table top size [mm]	Net price PRO SERIES	Net price PLUS SERIES	Net price ECO SERIES
1000x600			
1000x1000			
1200x800			
1200x1000			
1200x1200			
1500x1000			
1500x1480			
2000x1000			
2400x1200			
3000x1480			

Price list for tables with legs on wheels with a 28 mm or 16 mm hole system in a diagonal grid and for tables with a 16 mm hole system in a 50x50 mm grid:

Table top size [mm]	Net price PRO SERIES	Net price PLUS SERIES	Net price ECO SERIES
1000x600			
1000x1000			
1200x800			
1200x1000			
1200x1200			
1500x1000			
1500x1480			
2000x1000			
2400x1200			
3000x1480			

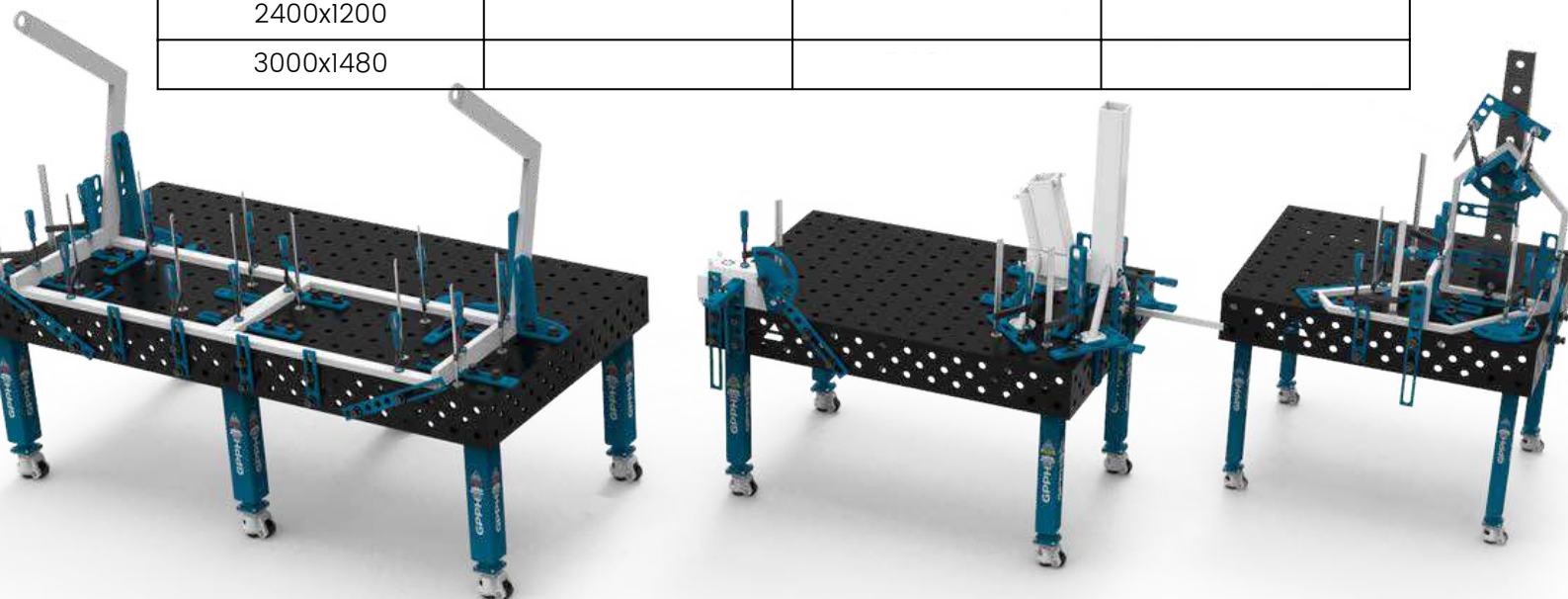

WELDING TABLES – TRADITIONAL

PRO, PLUS, and ECO series – stainless steel covers

For each welding table from the PRO, PLUS, and ECO series, you can buy a 1 mm thick stainless steel cover.

To transform the Traditional GPPH Welding Table into a table ideal for welding stainless steel, just put an overlay on it.

The hole patterns of the stainless steel cap are the same as the hole patterns of the GPPH welding tables.

Price list of stainless steel covers for tables with a fi 28 mm or fi 16 mm hole system in a 100x100 mm grid:

Table top size [mm]	Net price
1000x600	
1000x1000	
1200x800	
1200x1000	
1200x1200	
1500x1000	
1500x1480	
2000x1000	
2400x1200	

Price list of stainless steel covers for tables with a 28 mm or 16 mm hole system in a diagonal grid and for tables with a 16 mm hole system in a 50x50 mm grid:

Table top size [mm]	Net price
1000x600	
1000x1000	
1200x800	
1200x1000	
1200x1200	
1500x1000	
1500x1480	
2000x1000	
2400x1200	

WELDING TABLES – STAINLESS

INOX series – technical parameters

In our offer, you will find the Conventional Welding Tables GPPH INOX, which are available with **PRO** (15 mm) and **PLUS** (12 mm) series worktops. Each of them is available in ten versions of dimensions.

Stainless welding tables from the INOX series are made of 1.4301-grade stainless steel, which is characterized by better electrical conductivity than that of ordinary steel – electrical resistance at temperature 20°C = 0.73 ($\Omega \text{ mm}^2$)/m. You can use them where the precise welding of stainless steel is required.

Stainless welding tables are characterized by a high quality of execution and wear resistance. They are made of stainless steel with a high content of chromium which gives them **durability and corrosion resistance**. GPPH INOX welding tables ensure that there is no fear that iron will precipitate and that corrosion spots will be formed while welding stainless steel structures.

By using the INOX tables, your structures will be made **precisely and accurately** without any corrections. They ensure **ergonomic and effective work** while maintaining the high quality and repeatability of the executed structures. Moreover, the INOX tables series is also available in the version with legs on foot or wheels – the given table can be perfectly adapted to your needs.

Depending on your preferences, you may choose the INOX welding tables with worktops from the **PRO** or **PLUS** series with standard opening systems:

- fi 28 mm in a 100x100 mm grid
- fi 28 mm in a diagonal grid
- fi 16 mm in a 100x100 mm grid
- fi 16 mm in a diagonal grid
- fi 16 mm in a 50x50 mm grid

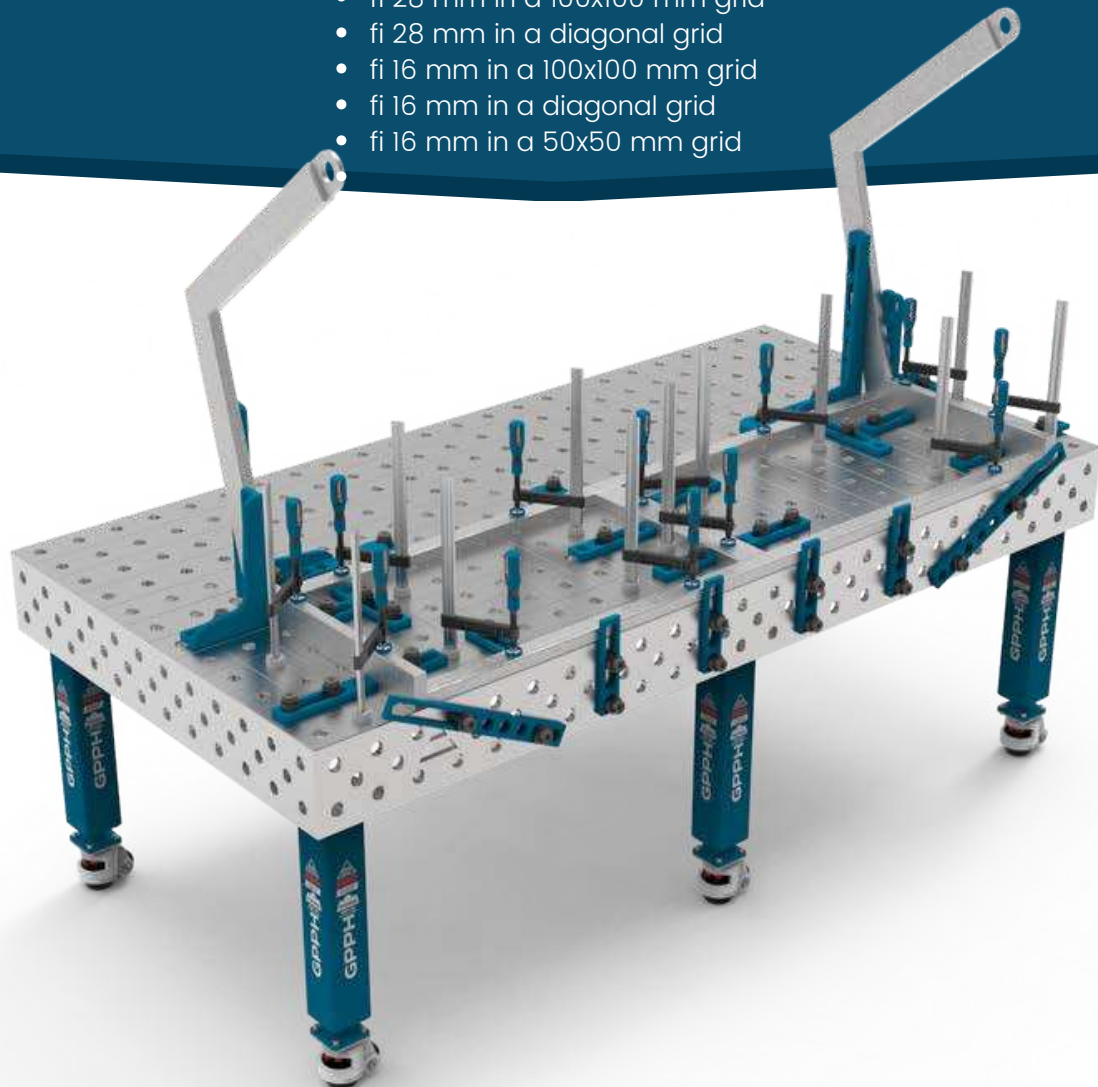

WELDING TABLES – STAINLESS

INOX series – technical parameters

Each worktop in the INOX version has an engraved pitch (more on the engraved pitch you will find on page 3). In addition, as in the case of conventional welding tables, the worktops have **robust and dense ribbing**, which affects the achievement of a **perfectly flat working surface** (tolerance on flatness ± 0.3 mm on the whole dimension of the worktop). The ribs are arranged every 400 mm on average. The robust and rigid structure of the worktop ensures maximum stability during operation and protects against deformation. The height of the sidewalls is 200 mm and they are made with a deviation tolerance of $\pm 0.3^\circ$.

On the INOX series welding tables with **PRO** worktops, you will use the PRO chamfered tools, while for the **PLUS** series worktops – the PLUS series tools. For works on the INOX tables, you may use the standard GPPH tools because they are powder coated. You will be able to execute precisely each flat and three-dimensional structure significantly faster using our tools! PRO series tools are presented on page 26, while the PLUS series is on page 27.

Our cleaning agents GPPH CHEM – **PROTECTOR** and **HD CLEANER** are the ideal solution for cleaning and protecting the INOX series welding tables (more information on page 35).

*Comparison of **PRO** and **PLUS** series worktops you will find on page 5.

INOX series welding tables with **PRO** and **PLUS** series worktops are available in the following dimensions: 3000x1480 mm, 2400x1200 mm, 2000x1000 mm, 1500x1480 mm, 1500x1000 mm, 1200x1200 mm, 1200x1000 mm, 1200x800 mm, 1000x1000 mm, 1000x600 mm.



WELDING TABLES – STAINLESS

INOX series – dimensions and price list – tables with legs on feet

Price list for INOX tables with legs on feet with a fi 28 mm or fi 16 mm hole system in a 100x100 mm grid:

Table top size [mm]	Net price PRO SERIES worktop	Net price PLUS SERIES worktop
1000x600		
1000x1000		
1200x800		
1200x1000		
1200x1200		
1500x1000		
1500x1480		
2000x1000		
2400x1200		
3000x1480		

Price list for INOX tables with legs on feet with a 28 mm or 16 mm hole system in a diagonal grid and for tables with a 16 mm hole system in a 50x50 mm grid:

Table top size [mm]	Net price PRO SERIES worktop	Net price PLUS SERIES worktop
1000x600		
1000x1000		
1200x800		
1200x1000		
1200x1200		
1500x1000		
1500x1480		
2000x1000		
2400x1200		
3000x1480		

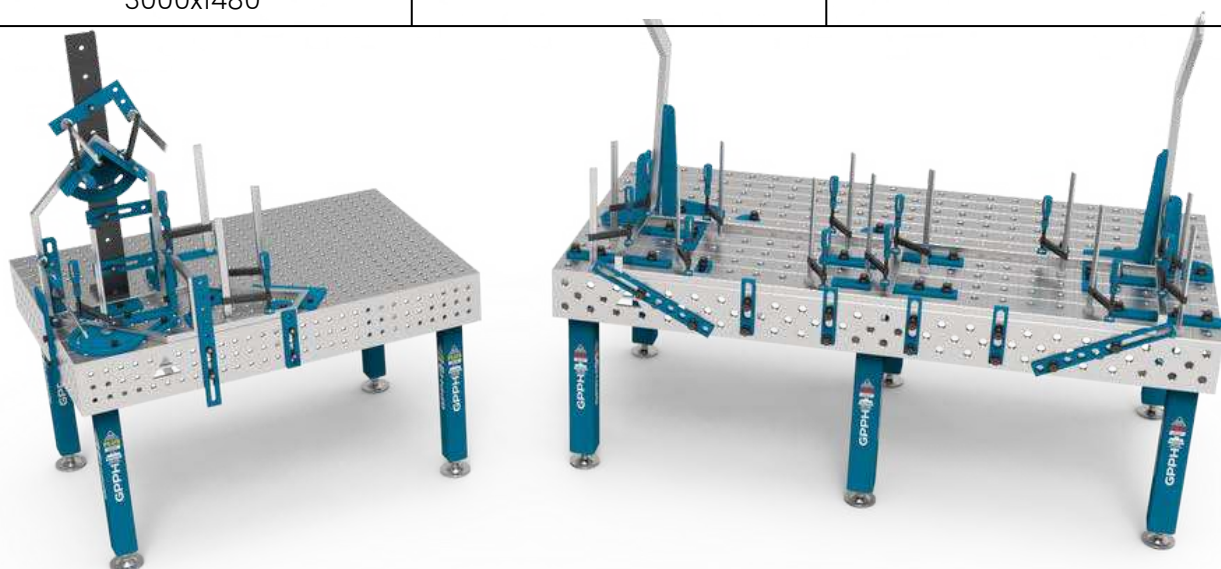

WELDING TABLES – STAINLESS

INOX series – dimensions and price list – tables with legs on wheels

Price list for INOX tables with legs on wheels with a fi 28 mm or fi 16 mm hole system in a 100x100 mm grid:

Table top size [mm]	Net price PRO SERIES worktop	Net price PLUS SERIES worktop
1000x600		
1000x1000		
1200x800		
1200x1000		
1200x1200		
1500x1000		
1500x1480		
2000x1000		
2400x1200		
3000x1480		

Price list for INOX tables with legs on wheels with a 28 mm or 16 mm hole system in a diagonal grid and for tables with a 16 mm hole system in a 50x50 mm grid:

Table top size [mm]	Net price PRO SERIES worktop	Net price PLUS SERIES worktop
1000x600		
1000x1000		
1200x800		
1200x1000		
1200x1200		
1500x1000		
1500x1480		
2000x1000		
2400x1200		
3000x1480		

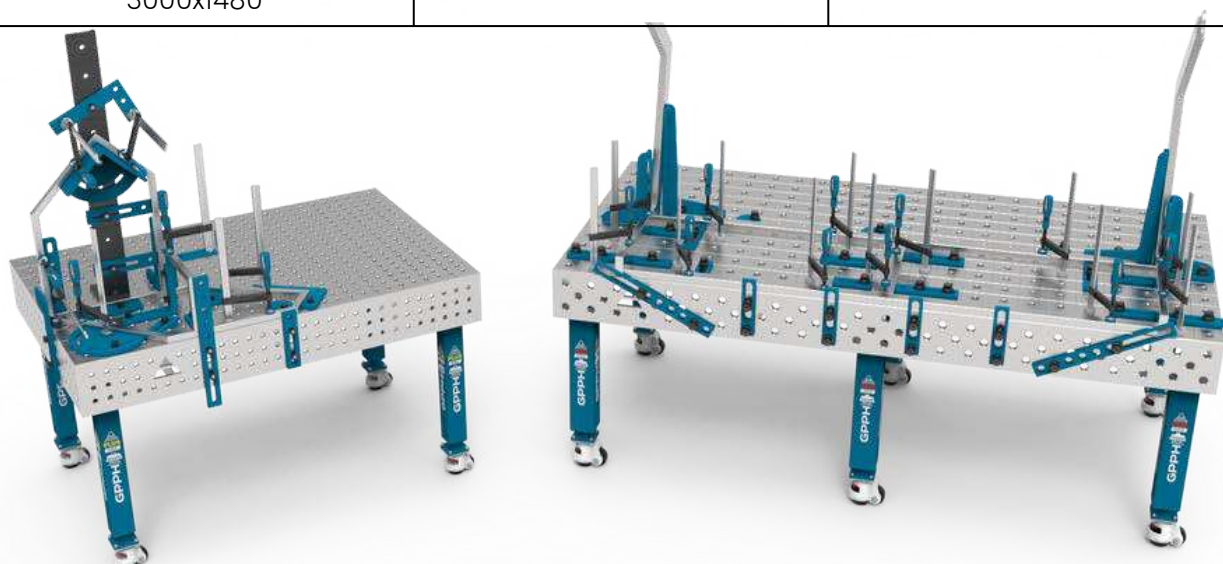

WELDING TABLES – MODULAR

MWT series – technical parameters

GPPH Modular Welding Tables are available in two variants of the top plates:

- material: S355J2+N
- material: tool steel subjected to the following treatment processes: nitriding + oxidation

The top of the modular tables consists of milled, sliding plates with a thickness of 15 mm, and by adjusting their surface, you will get **perfect flatness**. The plates are in a system of holes ϕ 28 mm in a 100x100 mm grid.

They have milled and chamfered holes to facilitate the assembly of tools. Modular tables are compatible with tools from the PRO series (more on page 256). In addition, the construction of our modular tables allows you to increase the number of mounting tools placed in the gaps between the tabletop boards – it's improving work ergonomics.

Modular tables have wheels with a foot in the basic legs, with a load capacity of 250 kg per leg. In the versions of extendable modular tables, there are adjustable supports in the additional legs. You can adjust the table high 850 mm – 1150 mm, P=50 mm.

You can combine the tables to get a larger work surface. Optionally, you can also purchase side plates.

Types of GPPH Modular Welding Tables:

- **SINGLE TABLE** – we offer three standard versions. They are ideal for small-scale production or serve as the basis for unlimited expansion of the surface of the welding station. They are in three dimensions: 1000x1000, 1200x1200, and 1600x1500.
- **EXTENDABLE SINGLE TABLE** – each table from our offer can be unfolded thanks to sliding plates and the use of additional legs. They are in three dimensions: 1770x1000, 2170x1200, and 2670x1600.
- **DOUBLE TABLE** – the most popular sets are sets composed of two single tables. The design of the tables allows expansion in every direction. They are in three dimensions: 2000x1000, 2400x1200, and 3200x1500.
- **SET WITH A LARGE WORK SURFACE** – connection of two unfolded tables by means of connectors is the perfect solution for spatial construction. They are in three dimensions: 2630x1770, 3030x2170, 4000x2670.



*the visualizations show Modular Welding Tables. From the top: Single table measuring 1200x1200 mm, Extendable single table measuring 2170x1200 mm, Double table measuring 2400x1200 mm, and Set with a large work surface measuring 2170x3030 mm. All tables in the visualizations have top plates made of S355J2+N steel.

WELDING TABLES – MODULAR

MWT series – dimensions and price list

Dimension [mm]	Material of the top plates: S355J2+N	Material of the top plates: tool steel subjected to the following treatment processes: nitriding + oxidation
SINGLE TABLE		
1000x1000		
1200x1200		
1600x1500		
EXTENDABLE SINGLE TABLE		
1770x1000		
2170x1200		
2670x1600		
DOUBLE TABLE		
2000x1000		
2400x1200		
3200x1500		
SET WITH A LARGE WORK SURFACE		
2630x1770		
3030x2170		
4000x2670		
SET OF SIDE PLATES		
for a single modular table with dimensions of 1000x1000		
for a single modular table with dimensions of 1200x1200		
for a single modular table with dimensions of 1600x1500		

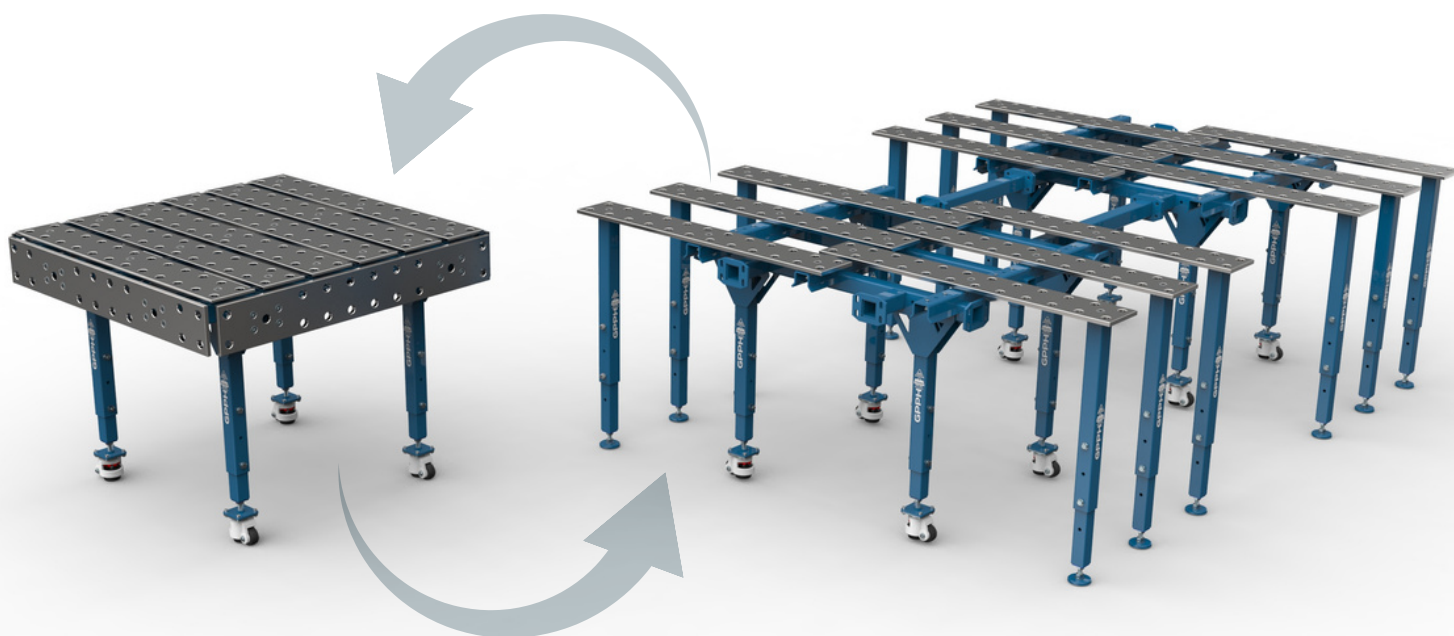

WELDING TABLES – WELDING & ASSEMBLY TABLES

BASIC series – technical parameters

WHERE WILL YOU USE THE BASIC WELDING TABLE? YOU CAN USE IT WHEREVER WELDING REQUIRES PRECISION.

It does not matter if your welding work is done classically by hand or you use welding robots – BASIC tables are a perfect choice! Your constructions will finally be made accurately, without unnecessary corrections!

We have an excellent solution for you if you use a welding robot for your work! The BASIC welding table is a perfect base for robotic welding and measuring stations. For such jobs, no side plates use. Therefore, the BASIC Welding Table meets all needs and is more cost-effective than Traditional Welding Tables with side plates.

Using milled tools from the PLUS series (see page 27), you will build an appropriate and easy-to-use work environment for making repeatable flat and spatial structures.

BASIC welding tables have:

- Perfectly flat work surface [± 0.3 mm on whole worktop];
- The massive and rigid base of the tabletop is 80mm high;
- Chamfered and milled holes for easy tool mounting, executed in tolerance $+0.05$ mm;
- Engraved scale in a 100x100mm grid;
- Height adjustment with standard legs approx. 880–930mm;
- All tables are rib reinforced, arranged every 400 mm on average;
- Milled table top edges;
- Tabletop thickness 12mm;
- Legs made of 60x60mm profile;
- Table load capacity up to 1,500 kg (250 kg/leg).

BASIC tables are available in the hole systems:

- fi 28 mm in a 100x100 mm grid;
- fi 16 mm in a 100x100 mm grid;
- fi 16 mm in a 50x50 mm grid;
- fi 16 mm in diagonal grid.

BASIC welding tables are available in the dimensions:

- 2400x1200,
- 2000x1000,
- 1500x1480,
- 1500x1000,
- 1200x1200,
- 1200x1000,
- 1200x800,
- 1000x1000,
- 1000x600.

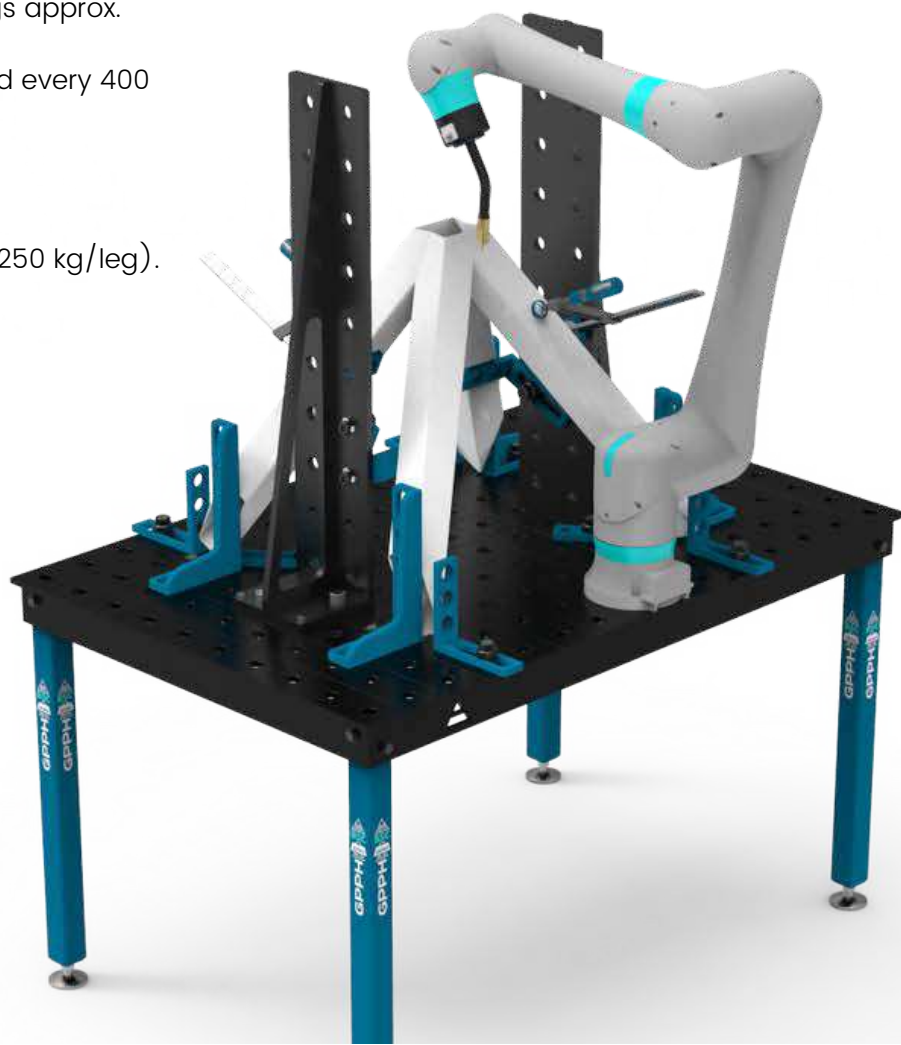

WELDING TABLES – WELDING & ASSEMBLY TABLES

BASIC series – dimensions and price list – tables with legs on feet

Price list for tables with legs on feet with a fi 28 mm or fi 16 mm hole system in a 100x100 mm grid:

Table top size [mm]	Net price
1000x600	
1000x1000	
1200x800	
1200x1000	
1200x1200	
1500x1000	
1500x1480	
2000x1000	
2400x1200	

Price list for tables with legs on feet with a 16 mm hole system in a diagonal grid and for tables with a 16 mm hole system in a 50x50 mm grid:

Table top size [mm]	Net price
1000x600	
1000x1000	
1200x800	
1200x1000	
1200x1200	
1500x1000	
1500x1480	
2000x1000	
2400x1200	

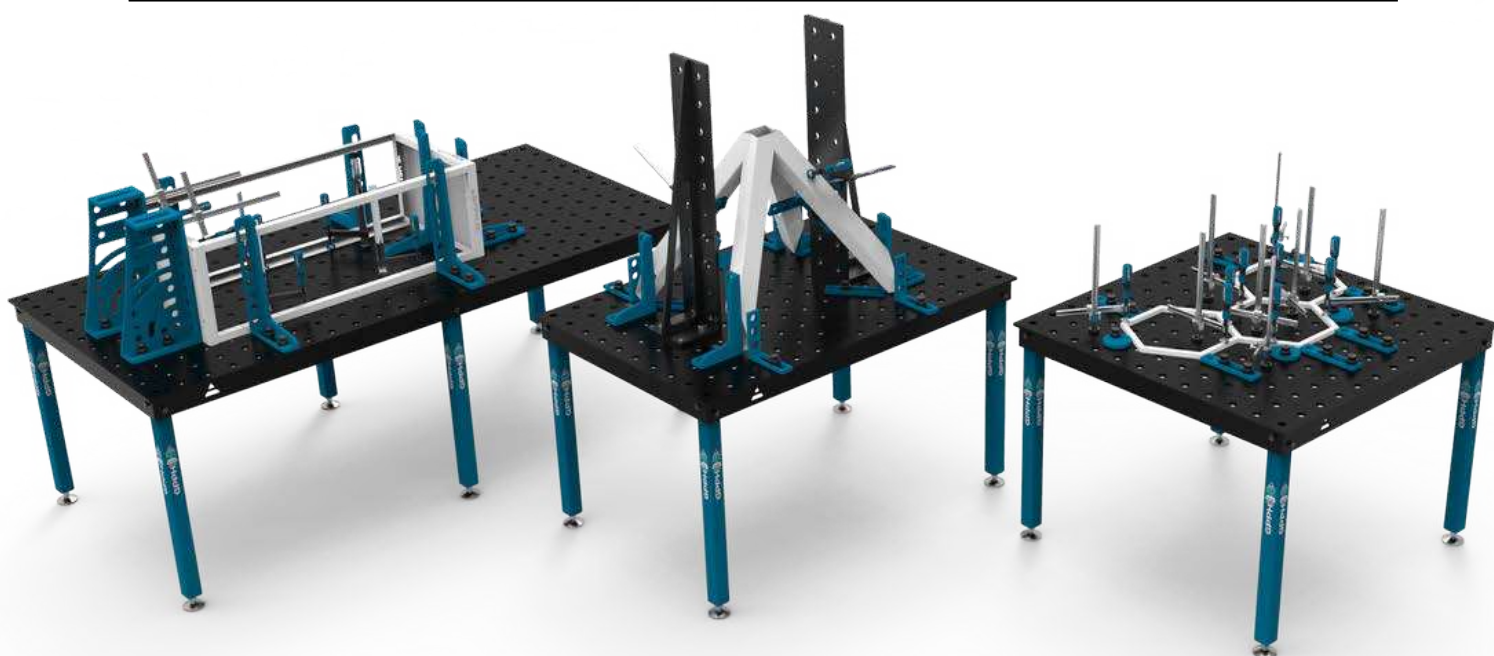

WELDING TABLES – WELDING & ASSEMBLY TABLES

BASIC series – dimensions and price list – tables with legs on wheels

Price list for tables with legs on wheels with a fi 28 mm or fi 16 mm hole system in a 100x100 mm grid:

Table top size [mm]	Net price
1000x600	
1000x1000	
1200x800	
1200x1000	
1200x1200	
1500x1000	
1500x1480	
2000x1000	
2400x1200	

Price list for tables with legs on wheels with a 16 mm hole system in a diagonal grid and for tables with a 16 mm hole system in a 50x50 mm grid:

Table top size [mm]	Net price
1000x600	
1000x1000	
1200x800	
1200x1000	
1200x1200	
1500x1000	
1500x1480	
2000x1000	
2400x1200	



WELDING TABLES – WELDING & ASSEMBLY TABLES

DIY series – technical parameters and price

The DIY Welding and Assembly Table has a dimension of 1200x800 mm and is available in the version of holes 16 mm in a 50x50 mm grid. The holes have an execution tolerance of ± 0.1 mm. In addition, the DIY table has an engraved scale in a 100x100 mm grid. The height of the table is 880 mm. The DIY welding and assembly table is made of S355J2+N material.

DIY tables are **densely ribbed**, which affects their perfect flatness [$\pm 0,5$ mm on the whole worktop]. In addition, they have equipped with leveling feet that level the unevenness of the floor.

The DIY table top is 8 mm thick. The maximum load capacity of the table is 500 kg. The table weight is approx. 90 kg. This product will be perfect not only for the welder and the DIY enthusiast, carpenter, and car mechanic, as an auxiliary table for CNC machines and various workshops.

For DIY tables, tools from the PLUS series are compatible with the fast assembly bolt 19-22 ECO/PLUS (see tools on page 27).

ASSEMBLY-WELDING TABLE DIY CONSISTS OF:

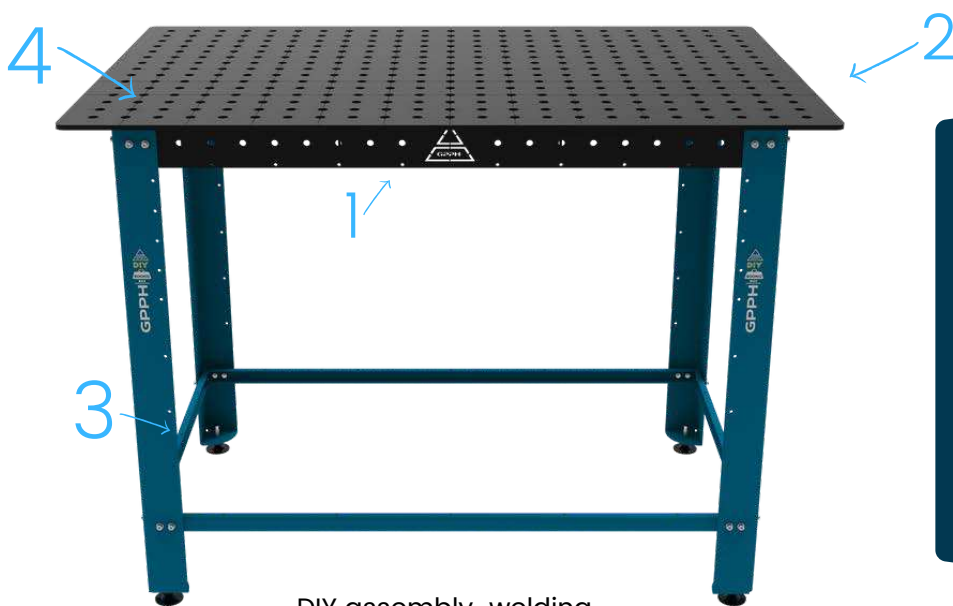

1. Metal rigid frame reinforced with ribs
2. Working table 8 [mm] thick made of S355J2+N steel
3. Legs equipped with leveling feet to compensate for unevenness of the flooring
4. Engraved scale in the grid 100x100 [mm] and assembly holes of system 16, in the grid 50x50 [mm]

DIY assembly-welding table net price:

ADDITIONAL ACCESSORIES FOR DIY TABLES:

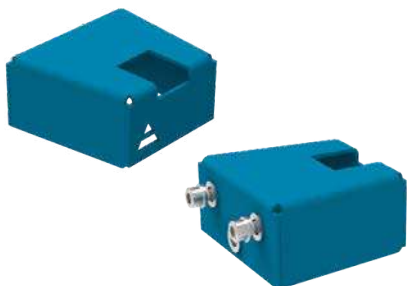

Adapter for tool shelves:



Set of wheels for DIY table:

WELDING TABLES – WELDING & ASSEMBLY TABLES

DIY series – toolkits

For DIY welding and assembly tables, we offer two ready-made sets of tools from the PLUS series (you can find a presentation of all tools in this series on page 27) fastened with a fast assembly bolt 19-22 ECO/PLUS (see on page 28).

Tool kit no. 1 included shelf adapters to fit a mobile tool shelf to the side of a DIY tabletop.



WELDING TABLES – LIFTING

with hydraulic lifting system – XWT series – technical parameters

GPPH welding tables with hydraulic lifting system are professional tables with automatic adjustment of table top height.

With it you will quickly and easily reach the ideal working height of the table top ensuring high comfort of work.

Welding tables with hydraulic lifting system are equipped with:

- overload valve preventing lifting too heavy loads;
- safety valve stopping the lowering in the case of rupture of the hydraulic lines;
- limit switches protecting against crushing or personal injury.

Welding tables with a hydraulic lifting system are available in the series of GPPH welding table tops:

- **PRO**, **PLUS**, and **ECO**, which are made of S355J2+N steel;
- **PRO INOX** and **PLUS INOX**, which are made of stainless steel of the 1.4301 grade.

(Differences between tabletop series can be found on page 5).

Each series is available in 7 sizes: 1200x1000 mm, 1200x1200 mm, 1500x1000 mm, 1500x1480 mm, 2000x1000 mm, 2400x1200 mm.

Furthermore, each table top is available with ϕ 28 mm holes in the grids: 100x100 mm and diagonal, and in the ϕ 16 mm holes system in the grids: 50x50 mm, 100x100 mm and diagonal.

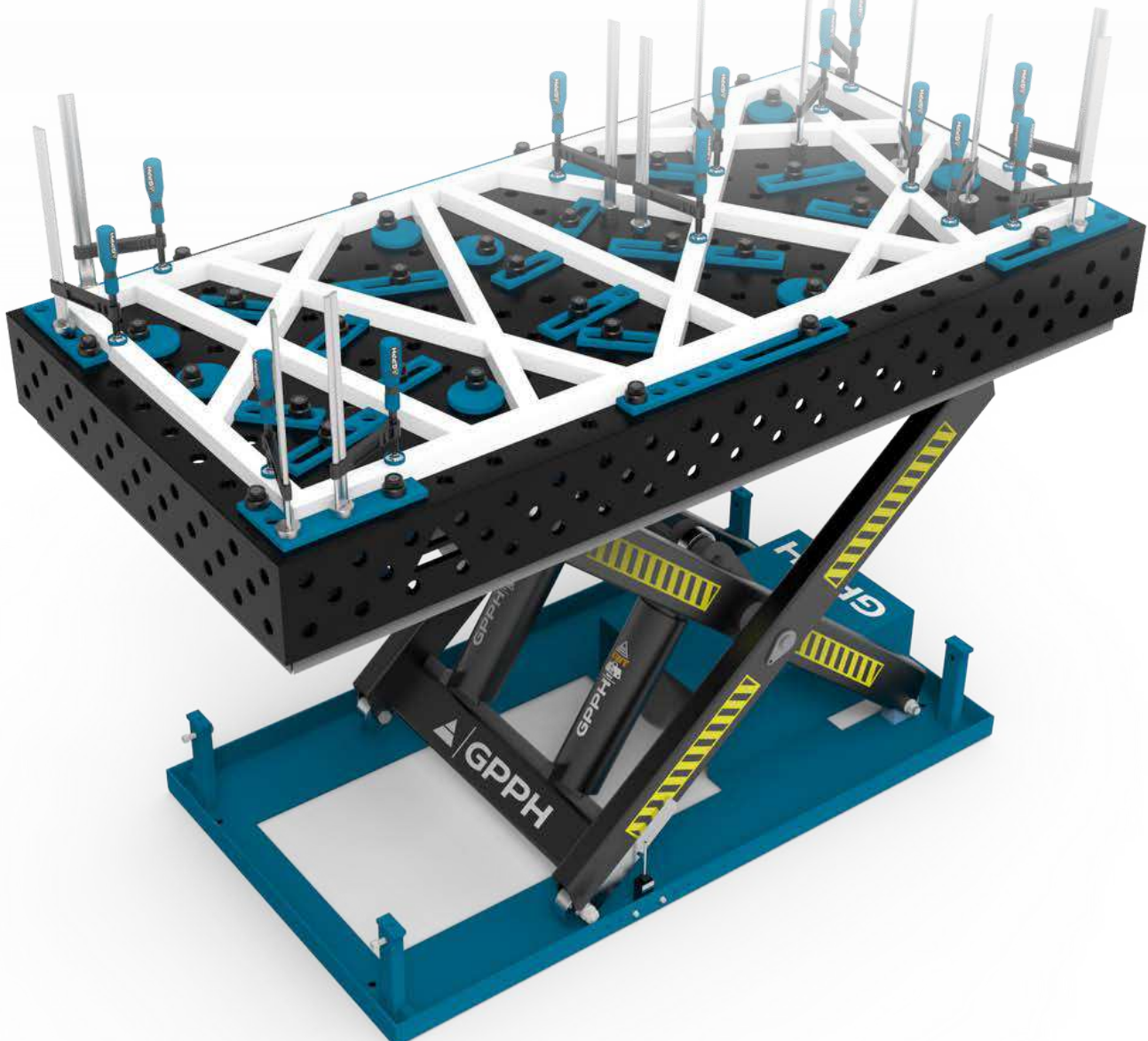

WELDING TABLES – LIFTING

with hydraulic lifting system – XWT series – technical parameters

Technical parameters of the base with hydraulic lifting system:

- supply voltage: 400 V
- revolutions: 1400 rpm
- protection class: IP54
- insulation class: F

Table dimensions [mm]	Max. load capacity [kg]	Lifting time with a load [s]	Max. table height [mm]	Min. table height [mm]	Dimensions of the base of the lifting [mm]	Motor power [kW]
1200x800	650	20-25	1140	435	1240x640	1.1
1200x1000						
1200x1200						
1500x1000	1600	20-25	1150	460	1220x785	2.2
1500x1480	1500	20-25	1450	480	1600x785	2.2
2000x1000	3500	30-40	1200	470	1600x900	2.2
2400x1200	3400	45-55	1550	530	1980x930	2.2

Weights of the GPPH welding tables with hydraulic lifting system:

Table dimensions [mm]	Weight of XWT with table top from the PRO series [kg]	Weight of XWT with table top from the PLUS series [kg]	Weight of XWT with table top from the ECO series [kg]
1200x800	416	366	286
1200x1000	466	406	316
1200x1200	496	426	336
1500x1000	638	568	468
1500x1480	779	679	559
2000x1000	865	775	655
2400x1200	1135	1015	845

WELDING TABLES – LIFTING

with hydraulic lifting system – XWT series – dimensions and price list

Price list for the tables with a top made of S355J2+N steel with fi 28 mm and fi 16 mm holes system in a 100x100 mm grid:

Table top dimension [mm]	PRO SERIES net price	PLUS SERIES net price	ECO SERIES net price
1200x800			
1200x1000			
1200x1200			
1500x1000			
1500x1480			
2000x1000			
2400x1200			

Price list for the tables with a top made of S355J2+N steel with fi 28 mm and fi 16 mm holes system in a diagonal grid and for tables with fi 16 mm holes system in a 50x50 mm grid:

Table top dimension [mm]	PRO SERIES net price	PLUS SERIES net price	ECO SERIES net price
1200x800			
1200x1000			
1200x1200			
1500x1000			
1500x1480			
2000x1000			
2400x1200			



WELDING TABLES – LIFTING

with hydraulic lifting system – XWT series – dimensions and price list

Price list for the tables with a top made of stainless steel, grade 1.4301, with fi 28 mm and fi 16 mm holes system in a 100x100 mm grid:

Table top dimension [mm]	PRO INOX SERIES net price	PLUS INOX SERIES net price
1200x800		
1200x1000		
1200x1200		
1500x1000		
1500x1480		
2000x1000		
2400x1200		

Price list for the tables with a top made of stainless steel, grade 1.4301, with fi 28 mm and fi 16 mm holes system in a diagonal grid and for tables with fi 16 mm holes system in a 50x50 mm grid:

Table top dimension [mm]	PRO SERIES net price	PLUS SERIES net price
1200x800		
1200x1000		
1200x1200		
1500x1000		
1500x1480		
2000x1000		
2400x1200		

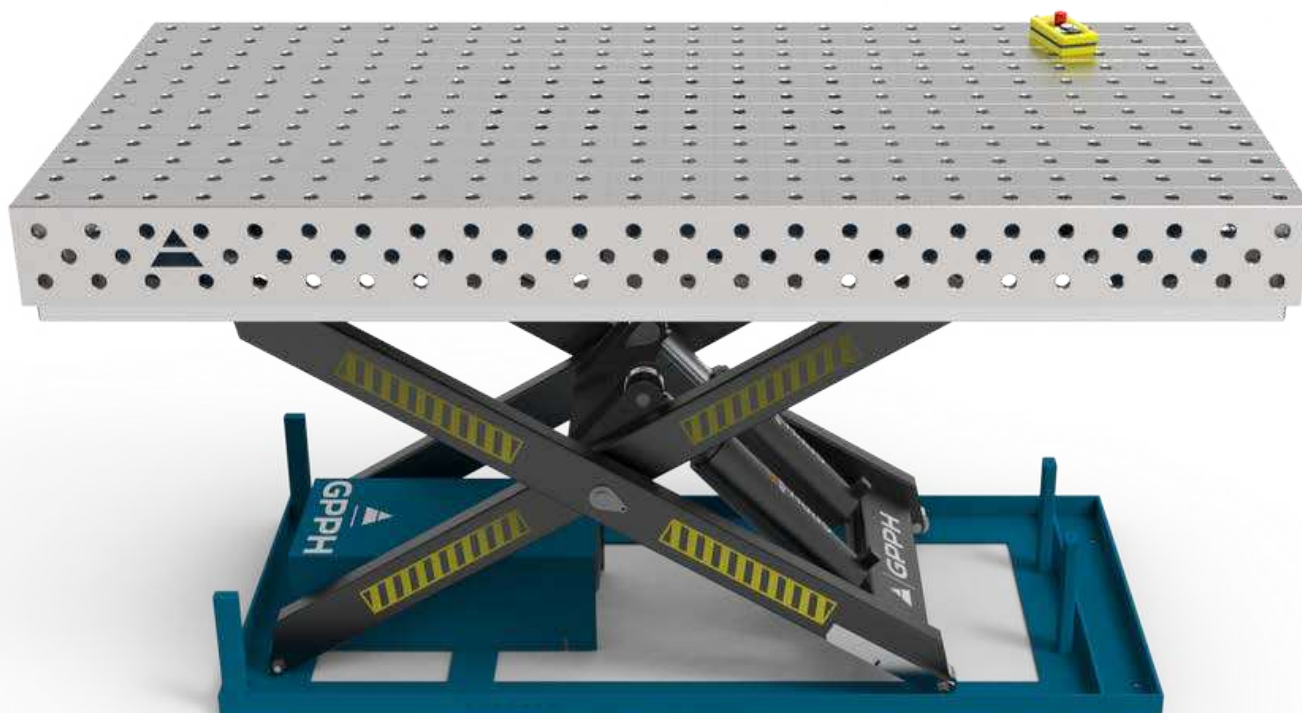

GRINDIG-WELDING STATION

SOG series – technical parameters

The grinding-welding station is intended for capturing and removing the dust and gases formed during grinding with a hand grinder or welding and metalworking operations. The station may be used with an exhaust fan or fan-powered filter equipment.

The GPPH grinding-welding station is available in three versions:

- Grinding-welding station – base
- Grinding-welding station – base with guards
- Grinding-welding station – base with top exhaust

The workstation base is adapted for the installation of guards and a top extraction system. Each variant of the grinding-welding station consists of a working table with a worktop made of 8 mm thick metal sheet.

Grinding-welding station is available in two versions of dimensions of the worktop:

- 1270x700 mm;
- 2000x900 mm.

Worktop has the assembly holes in a $\phi 28$ mm system with a 100x100 mm grid and additional holes for extraction of dust and gases.

Grinding-welding station with the covers is equipped with a back cover, while the variant with top extraction – the top extraction system. Both versions (with covers and top extraction) are equipped with tilting doors on the right and left – it allows positioning the items on the table which are longer than the width of the grinding-welding station.

Each SOG version is equipped with a connector $\phi 160$ mm installed in the side surface of the extraction trough. The air may be exhausted from the bottom through the table of extraction trough. All types of the grinding-welding station are equipped with an extraction trough with drawers, two 230V power outlets for the connection of power tools and a system for the connection of the lighting of the working space.

For GPPH grinding-welding stations, you can use PLUS series tools mounted with an adjustable 19–22 ECO/PLUS mandrel (see tools on page 27).



GRINDIG-WELDING STATION

SOG series - technical parameters and price list

Parameters for worktop with the dimensions:	1270x770 mm	2000x900 mm
BASE		
Weight	167 kg	225 kg
Resistance of flow	250 Pa	250 Pa
Recommended airflow for welding	1500 m ³ /h	2200 m ³ /h
Recommended airflow for grinding	3000 m ³ /h	4000 m ³ /h
Net price		
BASE WITH GUARDS		
Weight	190 kg	250 kg
Resistance of flow	250 Pa	250 Pa
Recommended airflow for welding	1500 m ³ /h	2200 m ³ /h
Recommended airflow for grinding	3000 m ³ /h	4000 m ³ /h
Net price		
BASE WITH TOP EXHAUST		
Weight	264 kg	315 kg
Resistance of flow	250 Pa	250 Pa
Recommended airflow for welding	1500 m ³ /h	2200 m ³ /h
Recommended airflow for grinding	3000 m ³ /h	4000 m ³ /h
Net price		

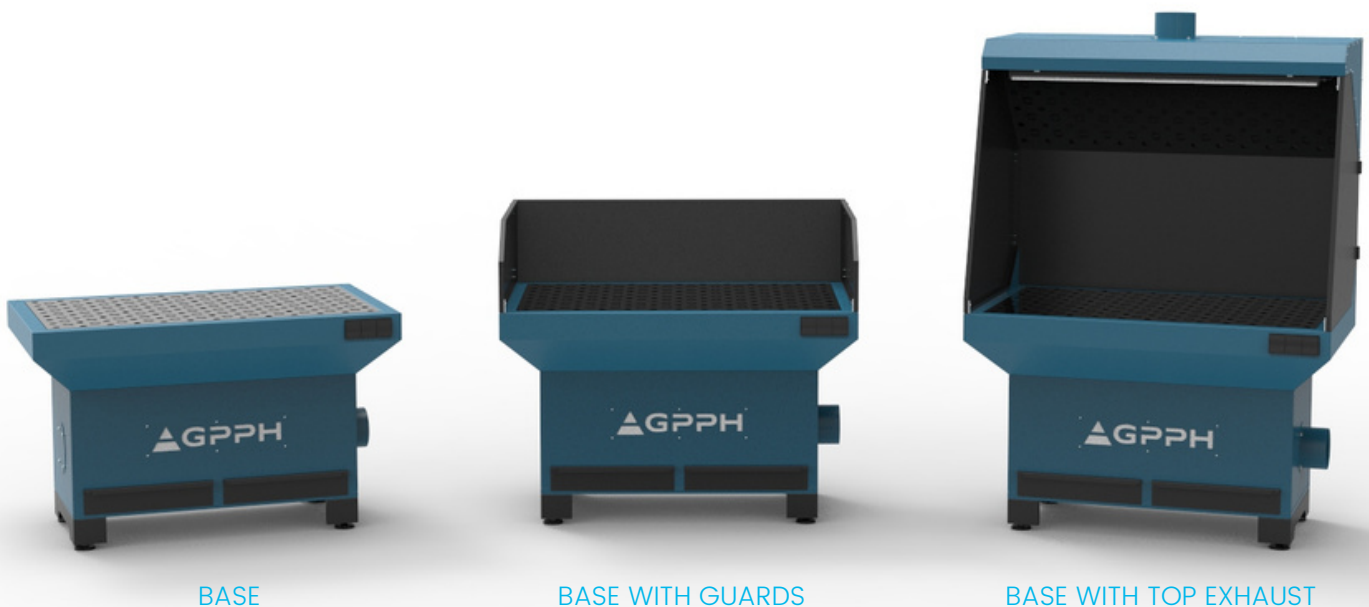

*The visualizations present a grinding-welding station with a worktop having the dimensions of 1270x700 mm.

PRO SERIES TOOLS

dedicated to tables: **PRO**, MWT and **XWT** with PRO series tops

Flat tools

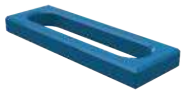

STOP PRO 150



STOP PRO 225

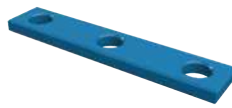

STOP PRO 260



STOP PRO 500



PROTRACTOR PRO



ANGLE PRECISION SQUARE
(FLAT) PRO 275x150



ANGLE PRECISION SQUARE
(FLAT) PRO 320x150



ANGLE PRECISION SQUARE
(FLAT) PRO 350x250

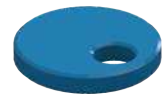

ECCENTRIC STOP
PRO Ø100mm

Spatial tools



ANGLE BRACKET
PRO 185x175



ANGLE BRACKET
PRO 200x200



ANGLE BRACKET
PRO 300x190



ANGLE BRACKET
PRO 450x250



ANGLE BRACKET
PRO 275x500x175x100

Increasing working surface



TABLE EXTENSION
PRO 1000X100



TABLE EXTENSION
PRO 1000X200

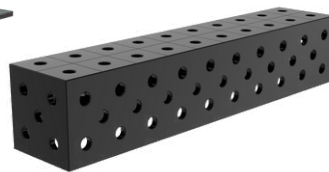

WELDING CONNECTION BLOCK
PRO 1000X200X200



WELDING CONNECTION BLOCK
PRO 1500X200X200

Assembly tools



MOUNTING PIN PRO



FAST ASSEMBLY BOLT
30 PRO



MAGNETIC FAST ASSEMBLY
BOLT PRO



FAST ASSEMBLY BOLT UNI

PLUS SERIES TOOLS

dedicated to tables: **PLUS**, **BASIC**, and **XWT** with PLUS series tops
as well as for tables: **ECO**, **DIY**, **XWT** with tops from the ECO series and for **SOG** stations**

Flat tools

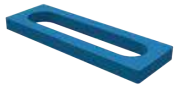

STOP PLUS 150

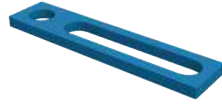

STOP PLUS 225

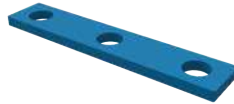

STOP PLUS 260



STOP PLUS 500



PROTRATOR PLUS



ANGLE PRECISION SQUARE
(FLAT) PLUS 275x150



ANGLE PRECISION SQUARE
(FLAT) PLUS 320x150



ANGLE PRECISION SQUARE
(FLAT) PLUS 350x250



ECCENTRIC STOP
PLUS Ø100mm

Spatial tools



ANGLE BRACKET
PLUS 185x175



ANGLE BRACKET
PLUS 200x200



ANGLE BRACKET
PLUS 300x190



ANGLE BRACKET
PLUS 450x250



ANGLE BRACKET
PLUS 275x500x175x100

Increasing working surface



TABLE EXTENSION
PLUS 1000X100



TABLE EXTENSION
PLUS 1000X200

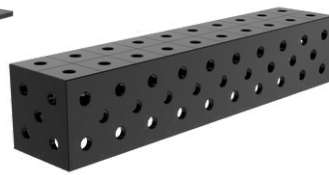

WELDING CONNECTION BLOCK
PLUS 1000X200X200

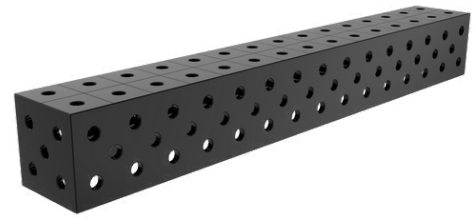

WELDING CONNECTION BLOCK
PLUS 1500X200X200

Assembly tools



MOUNTING PIN PLUS



FAST ASSEMBLY BOLT
23 PLUS



MAGNETIC FAST ASSEMBLY
BOLT PLUS



FAST ASSEMBLY BOLT UNI

*all tools are available in fi 16 mm and fi 28 mm holes.

**in this case (tables: ECO, DIY, XWT with an ECO series top and SOG stands), the tools are mounted with a fast assembly bolt 19-22 ECO/PLUS - you will find it on page 28.

ECO SERIES TOOLS

dedicated to increasing the working surface of ECO tables and for mounting PLUS series tools on tables: ECO, DIY, XWT series with ECO series tops and on SOG stations**

Increasing working surface



TABLE EXTENSION
ECO 1000X100



TABLE EXTENSION
ECO 1000X200



WELDING CONNECTION BLOCK
ECO 1000X200X200

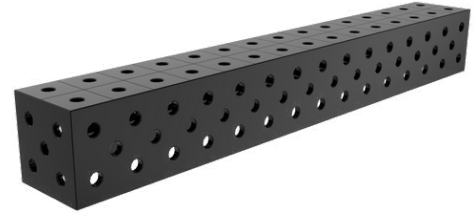

WELDING CONNECTION BLOCK
ECO 1500X200X200

Assembly tools



MOUNTING PINECO



FAST ASSEMBLY BOLT
19-22 ECO/PLUS



MAGNETIC FAST ASSEMBLY
BOLT PLUS



FAST ASSEMBLY BOLT UNI



*all tools are available in fi 16 mm and fi 28 mm holes.

**in this case, the tools are mounted using the 19-22 PLUS/ECO adjustable mandrel - you will find it on this page in the "Assembly tools" section

UNIVERSAL TOOLS

dedicated to all GPPH tables and stations

Fastening clamps



FASTENING CLAMP



FASTENING CLAMP
WITH LEVER



VARIABLE THROAT
DEPTH CLAMP



VARIABLE THROAT DEPTH
WITH LEVER CLAMP



FASTENING CLAMP



FASTENING CLAMP
WITH LEVER

Prisms, welding torch handle



PRISM Ø58MM 130°



PRISM Ø58MM 130°/90°



PRISM Ø58MM 90°



WELDING TORCH HANDLE

Mobile tool shelves

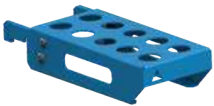

FAST ASSEMBLY BOLT SHELF S



FAST ASSEMBLY BOLT SHELF M



CLAMP SHELF S



CLAMP SHELF M

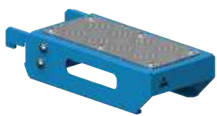

FLAT SHELF S

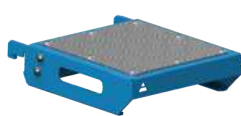

FLAT SHELF M



FLAT SHELF L

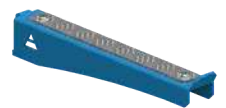

MOBILE SHELF FOR EXTENSIONS



MIX SHELF



DOCUMENTATION SHELF

TOOL TROLLEYS

maintaining order at the workplace

Tool trolley M



One of the many advantages of the small tool trolley is that it fits under most dimensions of GPPH Welding Tables. You have all the tools at your fingertips while working!

Tool trolley L



The large GPPH tool trolley will accommodate a set of tools even for the most demanding user! Thanks to it, your workplace will become transparent like never before, and GPPH tools will be clearly arranged and more accessible.

*tool trolleys are available in the version of holes fi 16 mm and fi 28 mm. You can check the price of tool trolleys on page 32

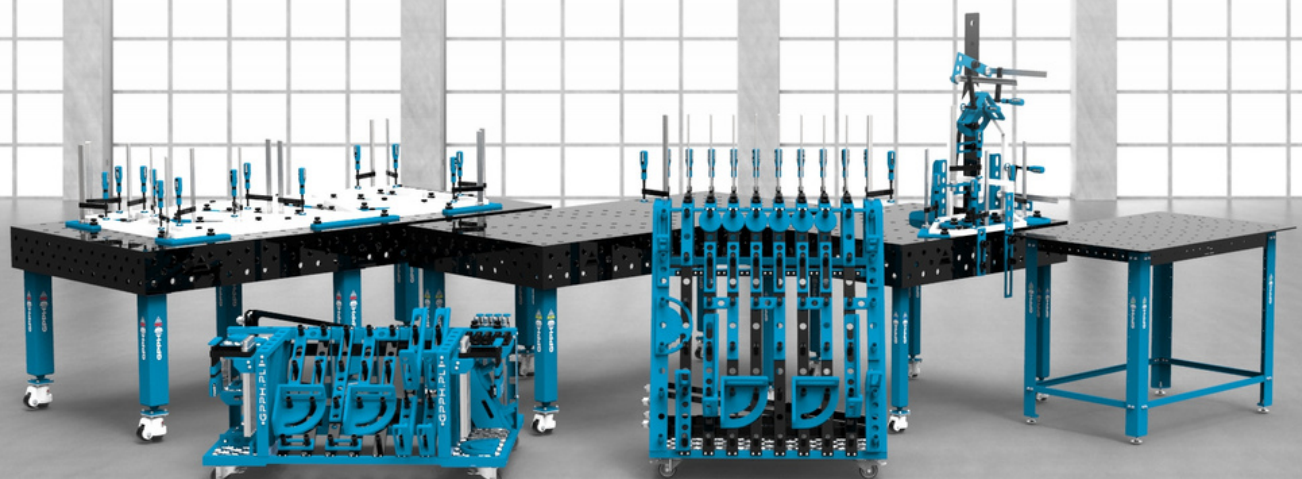

TOOLS

price list

TOOL	PRICE		
	PRO SERIES	PLUS SERIES	ECO SERIES
FLAT TOOLS			
Stop 150			
Stop 225			
Stop 260			
Stop 500			
Protractor			
Angle precision square (flat) 275x150			
Angle precision square (flat) 320x150			
Angle precision square (flat) 350x250			
Eccentric stop Ø100			
SPATIAL TOOLS			
Angle bracket 185x175			
Angle bracket 200x200			
Angle bracket 300x190			
Angle bracket 450x250			
Angle bracket 275x500x175x100			
INCREASING WORKING SURFACE			
Table extension 1000x100			
Table extension 1000x200			
Welding connection block 1000x200x200 Ø16 mm, grid 50x50 mm			
Welding connection block 1000x200x200 Ø16 mm / Ø28 mm, grid 100x100 mm			
Welding connection block 1500x200x200 Ø16 mm, grid 50x50 mm			
Welding connection block 1500x200x200 Ø16 mm / Ø28 mm, grid 100x100 mm	---		
ASSEMBLY TOOLS			
Mounting pin			
Fast assembly bolt 30 PRO			
Fast assembly bolt 23 PLUS			
Fast assembly bolt 19-22 ECO/PLUS			
Magnetic fast assembly bolt PRO			
Magnetic fast assembly bolt PLUS			
Fast assembly bolt UNI			

TOOLS

price list

TOOL	PRICE
FASTENING CLAMPS	
Fastening clamp	
Fastening clamp with lever	
Variable throat depth clamp	
Variable throatdepth with lever clamp	
Fastening clamp	
Fastening clamp with lever	
PRISMS, WELDING TORCH HANDLE	
Prism Ø58mm 130°	
Prism Ø58mm 130°/90°	
Prism Ø58mm 90°	
Welding torch handle	
MOBILE TOOL SHELVES	
Fast assembly bolt shelf S	
Fast assembly bolt shelf M	
Clamp shelf S	
Clamp shelf M	
Flat shelf S	
Flat shelf M	
Flat shelf L	
Mobile shelf for extensions	
MIX shelf	
Documentation shelf	
TOOL TROLLEYS	
Tool trolley M	
Tool trolley L	

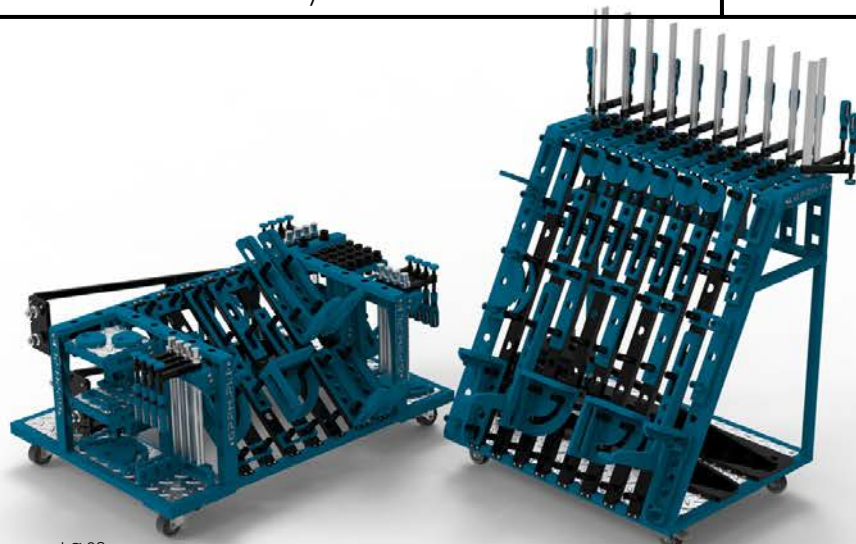

TOOLKITS

each toolkit is available in the PRO and PLUS series tool**

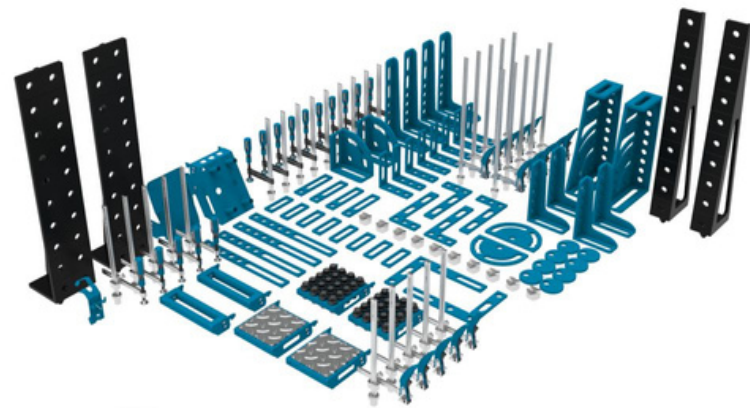

TOOLKIT

146
pieces

no.1



trolley
to choose
from:

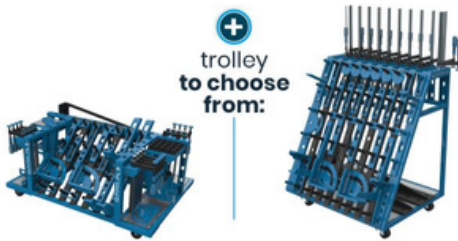

Price of toolkit no. 1 of the PRO series tool:
Price of toolkit no. 1 of the PLUS series tool:

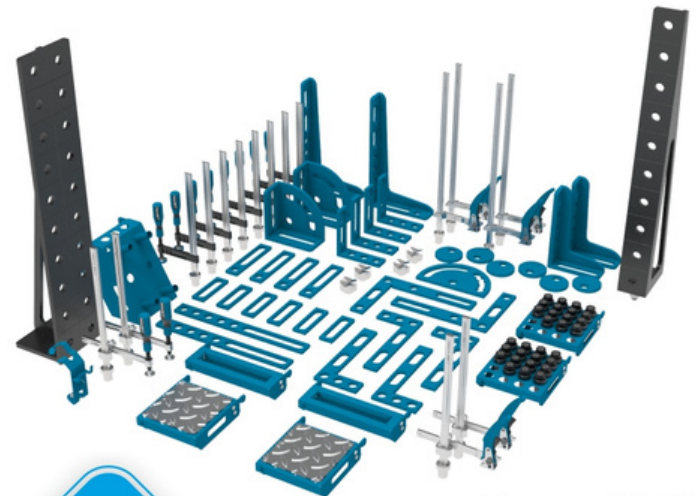

TOOLKIT

96
pieces

no.2



trolley
to choose
from:

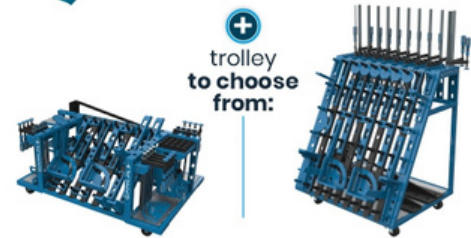

Price of toolkit no. 2 of the PRO series tool:
Price of toolkit no. 2 of the PLUS series tool:

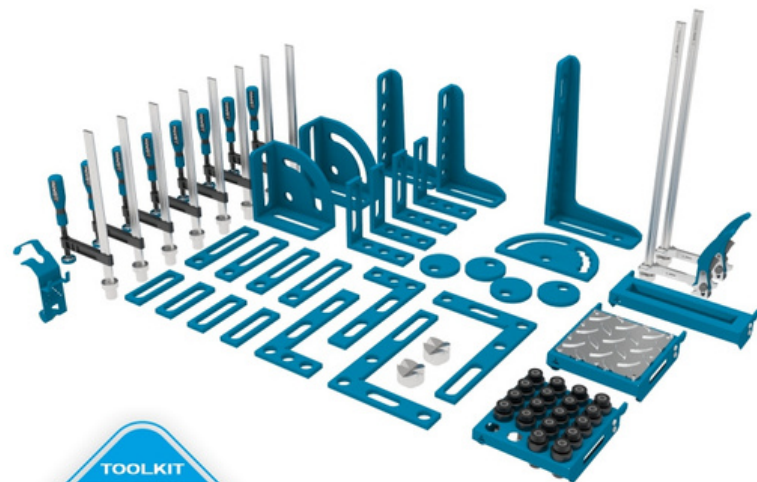

TOOLKIT

60
pieces

no.3

Price of toolkit no. 3 of the PRO series tool:
Price of toolkit no. 3 of the PLUS series tool:

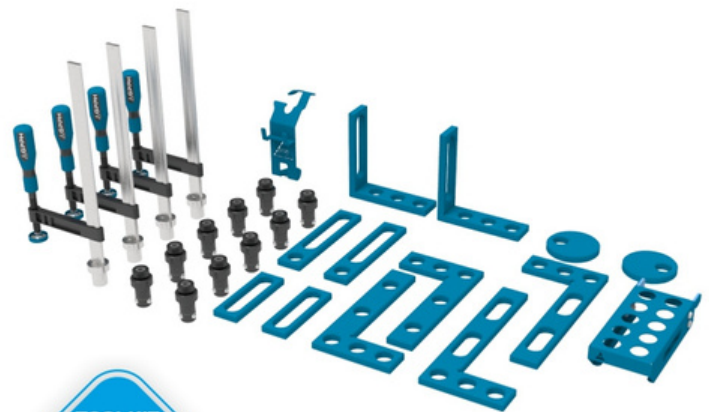

TOOLKIT

28
pieces

no.4

Price of toolkit no. 4 of the PRO series tool:
Price of toolkit no. 4 of the PLUS series tool:

*all tools are available in the version Ø 16 mm and Ø 28 mm.

**in the case of sets with tools from the PLUS series, depending on the thickness of the tabletop, the fast assembly bolt included in the set changes - in the case of PLUS, BASIC, and XWT tables with PLUS series top, it is the Fast assembly bolt 23 PLUS, and in the case of ECO, DIY, XWT tables with ECO series top and SOG stations, it is fast assembly bolt 19-22 ECO/PLUS.

TOOLKITS

each toolkit is available in the PRO and PLUS series tool**

Number of tools included in the set				
Tool	Toolkit no. 1	Toolkit no. 2	Toolkit no. 3	Toolkit no. 4
Fastening clamp	10	8	8	4
Fastening clamp with lever	10	4	2	-
Variable throat depth clamp	5	2	-	-
Variable throatdepth with lever clamp	5	2	-	-
Fast assembly bolt 30	40	30	18	10
Eccentric stop Ø100	8	6	4	2
Stop 150	8	6	4	2
Stop 225	4	4	4	2
Stop 500	4	2	-	-
Protractor	2	1	1	-
Angle precision square (flat) 275x150	-	-	-	2
Angle precision square (flat) 320x150	4	4	2	2
Angle precision square (flat) 350x250	2	2	2	-
Angle bracket 185x175	8	4	4	2
Angle bracket 200x200	2	2	2	-
Angle bracket 300x190	4	2	2	-
Angle bracket 450x250	4	2	1	-
Angle bracket 275x500x175x100	2	-	-	-
Table extension 1000x100	2	1	-	-
Table extension 1000x200	2	1	-	-
Welding torch handle	1	1	1	1
Prism Ø58mm 130°	10	-	-	-
Prism Ø58mm 130°/90°	-	4	2	-
Tool trolley (versions to choose: M or L)	1	1	-	-
Fast assembly bolt shelf S	-	-	-	1
Fast assembly bolt shelf M	2	2	1	-
Clamp shelf M	2	2	1	-
Flat shelf M	2	2	1	-
MIX shelf	1	1	-	-
Documentation shelf	1	-	-	-
The total number of tools included in the set	146	96	60	28

